

SK80/4A-WS211A

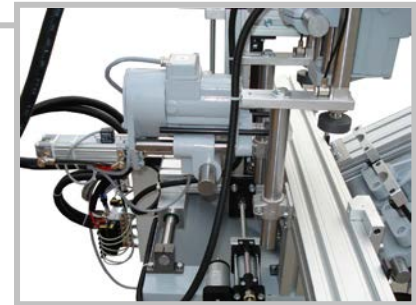
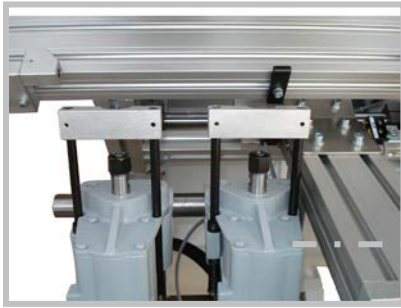

SK80/4A-WS211A

SK80/4A-WS211A

 **Wasserschlitzzfräsmaschine manuell / automatisch**







Die automatische Wasserschlitzzfräsmaschine ist mit 4 Drehstrommotoren ausgestattet. Motor 11.800 U/min, Handradverstellungen mit Skala, pneumatische Doppelspannung, Profilanschlag links und rechts, Wahlschalter für Wasserschlitze aussen/unten. Druckluftanschluss 6-8 bar. Revolver-Anschlag 6-Fach, Stahlblechständer.

 **Waterslot drainage milling machine manual / automatic**

Automatic waterslot drainage milling machine equipped with 4 motors. 3-Phase-Motor 11.800 rpm, adjustment by handwheel with scale. Compressed air connection 6-8 bar. Pneumatic workpiece clamping doubled, revolver stop with 6 depth positions. steel base.

 **Fraiseuse manuelle**

Fraiseuse écoulement d'eau SK80 / 4A Automatique 4 moteurs triphasés à déplacement automatique et passage d'un profilé de 180mm. Raccordement à l'air 6-8 bar. Serrage vertical, butée revolver 6 positions. Equipement sur demande : Ensemble 2 supports profilés avec pieds.

Modell						
SK80/4M-WS211M [manuell/manual]	380 V 50Hz	11.800 U/min	6-8 bar	(3x VHM) 5x25x60 S5 Z1 (1x VHM) 5x40x80 S5 Z1	135 kg	[mm] L= 1050 B= 850 H=1600
SK80/4A-WS211A [automatisch/automatic]	380 V 50Hz	11.800 U/min	6-8 bar	(3x VHM) 5x25x60 S5 Z1 (1x VHM) 5x40x80 S5 Z1	140 kg	[mm] L= 1050 B= 850 H=1600