

**KFM-3A-Stahl**

Artikel-Nr. 3061



**KFM-3A-Stahl**

**-90°**

**-45°**

**0°**

**+45°**

**+90°**

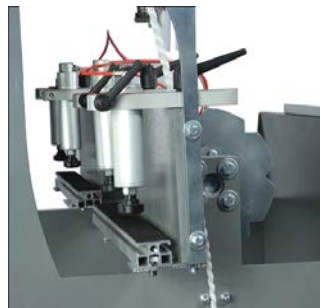

**-45°**

**+45°**

**-90°**

**+90°**

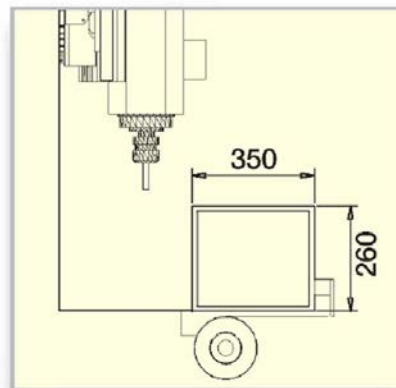
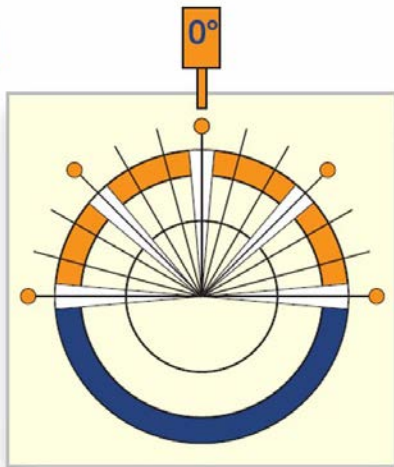

\* Kopierfräsmaschine

\* Single head copy router

\* Fraiseuse à copier

<p><b>Kopierfräsmaschine</b> KFM-3A-Stahl [3061]</p> 	<p><b>Single Head Copy Router</b> KFM-3A-Stahl [3061]</p> 	<p><b>Fraiseuse à copier</b> KFM-3A-Stahl [3061]</p> 
<p><b>Technische Daten</b></p> <p>3 Achsen Kopierfräsmaschine mit pneumatischer Sprüheinrichtung und 3 pneumatischen Kopierstiften. Komplet mit drehbarem Arbeitstisch -90°/-45°/0°/+45°/+90°. Einfache und schnelle Positionierung der Kopierstifte. Spindel Drehzahl von 2800 bis 12000Upm durch Umschaltgetriebe und Potentiometer. Arbeitsfläche 630x350x260mm. Bewegung der Axen auf Linearführungen. Komplet mit 4 pneumatik Spann-zylindern. Die Maschine ist für die Verarbeitung von Inox und Stahl konzipiert.</p>	<p><b>Technical Datas</b></p> <p>Copy router operating on 3 axes, with pneumatic lubrication, 3 pneumatic tracer points. Equipped with turning table at -90°/-45°/0°/+45°/+90°. Quick and easy adjustment of the tracer points. Equipped with variable speed spindle adjusted by inverter and potentiometer (from 2800 to 12000rpm) with Threephase motor 1,5HP. Working capacities 630x350x260 mm. Mouvement of the axis on linear guides. With 4 movable pneumatic clamps. Specially adressed for working on inox and steel.</p>	<p><b>Donnees Techniques</b></p> <p>Fraiseuse à Copier travaillant sur 3 axes, avec lubrification pneu- matique et 3 tâteurs pneu- matiques. Equipée avec table tournante de -90°/-45°/0°/+45°/+90°. Système de positionnement facile et rapide des tâteurs. Equipée avec mandrin à vitesse variable géré par inverter et potentiomètre (de 2800 à 12000tpm) avec moteur triphasé 1,5CV. Capacité de fraisage 630x350x260 mm. Deplacement des axes sur guides lineaires. Equipée avec 4 étaux pneu- matiques. Machine conçue parti- culièrement pour acier inox et fer.</p>
<p><b>Standard Zubehör</b></p> <ul style="list-style-type: none"> <li>- 4 pneumatische Spannungen</li> <li>- 3 pneumatische Kopierstiften mit Ø 5/8/10mm</li> <li>- 5 Profilanschläge</li> <li>- 1 Kopierschablone</li> <li>- Sprüheinrichtung</li> <li>- Wartungseinheit</li> <li>- Ausblaspistole</li> <li>- Bedienschlüssel</li> </ul>	<p><b>Standard Equipment</b></p> <ul style="list-style-type: none"> <li>- 4 pneumatic clamps</li> <li>- 3 tracer points with 3 diameters: Ø 5/8/10mm</li> <li>- 5 manual stops</li> <li>- 1 copy template for standard exec.</li> <li>- Pneumatic spray mist lubrication</li> <li>- Air filter</li> <li>- Air gun</li> <li>- Service keys</li> </ul>	<p><b>Equipement Standard</b></p> <ul style="list-style-type: none"> <li>- 4 étaux pneumatiques</li> <li>- 3 tâteurs à 3 diamètre: Ø 5/8/10mm</li> <li>- 5 étaux manuels</li> <li>- 1 gabarit pour travail standard</li> <li>- Dispositif de pulvérisation</li> <li>- Unitè de conditionnement de l'air Soufflette</li> <li>- Clès de service</li> </ul>
<p><b>Optionen</b></p> <ul style="list-style-type: none"> <li>- Kopierstift mit Digitalanzeige</li> <li>- Spannzange Ø 10mm</li> <li>- Unbearbeitete Kopierschablone</li> <li>- Sprühmittelemulsion 20 l</li> </ul>	<p><b>Options</b></p> <ul style="list-style-type: none"> <li>- Tracer points with digital reading</li> <li>- Collet Ø 10mm</li> <li>- Virgin template</li> <li>- Emulsified cutting oil 20 l</li> </ul>	<p><b>Equipement sûr demande</b></p> <ul style="list-style-type: none"> <li>- Tateurs avec visuliation digital</li> <li>- Pince Ø 10mm</li> <li>- Gabarit vièrge</li> <li>- Huile émulsionée 20 l</li> </ul>

<b>Abmessungen – Dimensions – Encombrement</b>				<b>Gewicht</b>	
	<b>L</b>	<b>W</b>	<b>H</b>	<b>Weight – Poids</b>	
<b>KFM-3A-Stahl</b>	1350mm	1050mm	1850mm	380 kg	